

- BLANK SET-UP SHEET -

Capricorn RC

Front

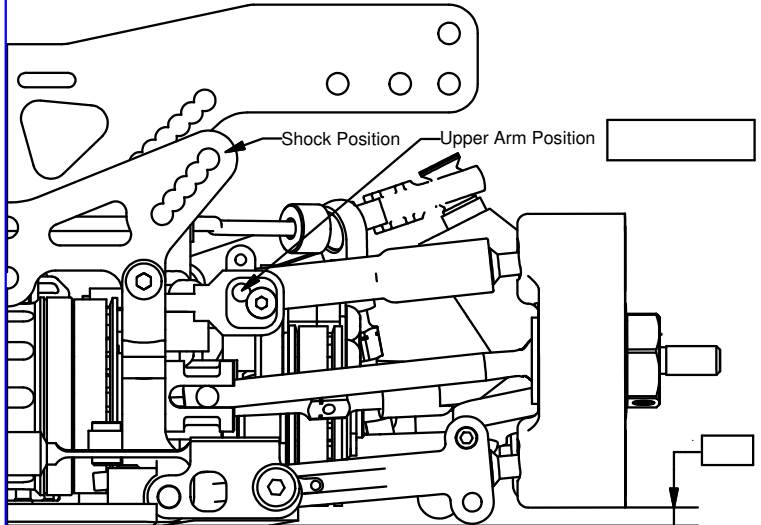
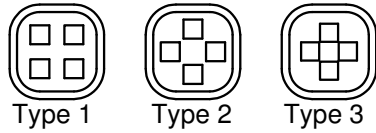

| | | | |
|-----------------------------------|------------------------------|------------------------------|------------------------------|
| FRONT | | REAR | |
| LEFT | RIGHT | TYRES | LEFT |
| | | TYPE | |
| | | SHORE | |
| | | DIAMETER | |
| SHOCK ABSORBERS | | | |
| OIL SPRING | | | |
| 1 2 3 | 1 2 3 | 1 2 3 | 1 2 3 |
| 4 5 6 | 4 5 6 | 4 5 6 | 4 5 6 |
| DAMPING | | | |
| ANTI-ROLL BARS | | | |
| <input type="checkbox"/> 0° | <input type="checkbox"/> 30° | <input type="checkbox"/> 45° | <input type="checkbox"/> 60° |
| <input type="checkbox"/> 90° | | | |
| Wire <input type="checkbox"/> 0,9 | <input type="checkbox"/> 1,0 | <input type="checkbox"/> 1,1 | |
| <input type="checkbox"/> 2,0 | <input type="checkbox"/> 2,1 | <input type="checkbox"/> 2,2 | <input type="checkbox"/> 2,3 |
| <input type="checkbox"/> 2,4 | | | |
| 1 ST | SPUR GEAR | 2 ND | |
| <input type="checkbox"/> 52 | <input type="checkbox"/> 53 | <input type="checkbox"/> 54 | |
| <input type="checkbox"/> 47 | <input type="checkbox"/> 48 | <input type="checkbox"/> 49 | |
| 1 ST | PINION | 2 ND | |
| <input type="checkbox"/> 14 | <input type="checkbox"/> 15 | <input type="checkbox"/> 19 | <input type="checkbox"/> 20 |
| DRIVE TRAIN | | | |
| MIDDLE AXLE PULLEY | | <input type="checkbox"/> 25 | <input type="checkbox"/> 26 |
| ENGINE | | | |
| TYPE PLUG | | MUFFLER NITRO | |
| BODY TYPE | | | |
| SET-UP SHEET | | | |
| NAME | | | |
| DATE | | | |
| TEMP | | | |
| TRACK | | | |
| TRACTION | | | |
| RESULT | | BEST LAP | |

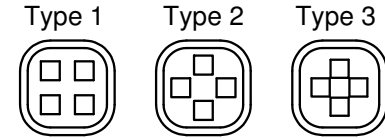

Rear

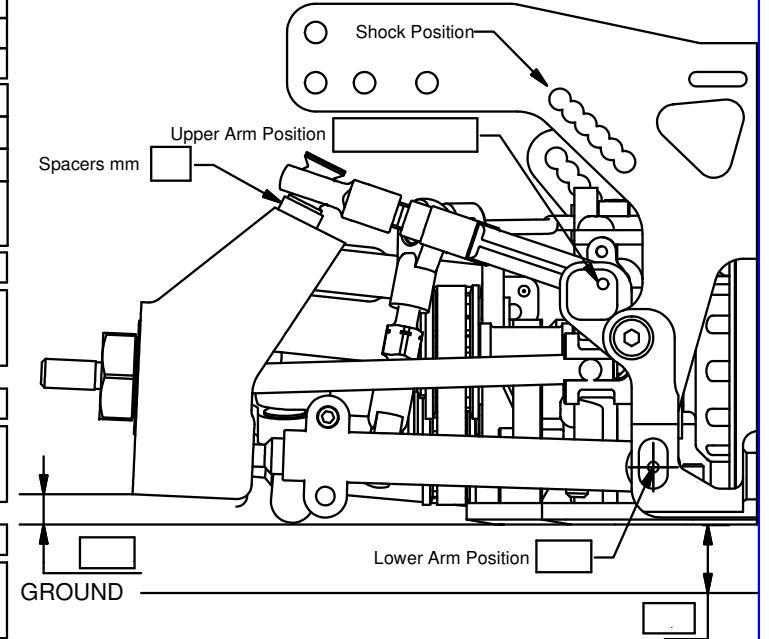

| | | |
|-------------------|-------------------------------|--------------------------|
| CAMBER | TOE | WIDHT |
| LEFT | | |
| RIGHT | | |
| WHEEL BASE | | GEAR DIFF. OIL |
| SHORT | <input type="checkbox"/> LONG | <input type="checkbox"/> |

Additional notes

| | | |
|--------------------------|-------------------------------|-------------------------------|
| CAMBER | TOE | WIDHT |
| LEFT | | |
| RIGHT | | |
| ACKERMANN INSERTS | | GEAR DIFF. OIL |
| 10mm | <input type="checkbox"/> 11mm | <input type="checkbox"/> 12mm |

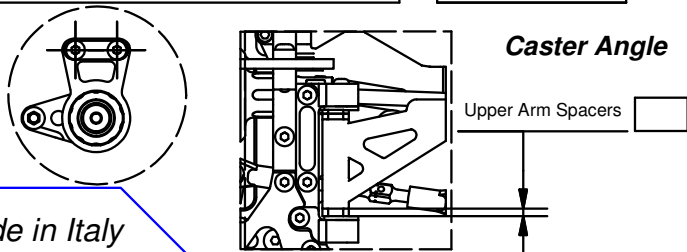

Made in Italy